

BILL OF MATERIAL			
ITEM	QTY	DESCRIPTION	DWG NO
1	1	FRONT ROD FOR POINT DETECTOR/LOCK RODS NO 10-136-1	SD-2539
2	1	SWITCH ROD NO 10-136-2	SD-2539
3	1	SWITCH ROD NO 10-136-3	SD-2539
4	2	ROD POINT BRACKET ASSEMBLY, 136 LB RE HOLES @ 2 7/8" ABOVE RAIL BASE	-
5	1	ROD POINT BRACKET FOR HST, ANTI-ROLL, HOLES @ 2 7/8" ABOVE RAIL BASE, LH	-
6	1	ROD POINT BRACKET FOR HST, ANTI-ROLL, HOLES @ 2 7/8" ABOVE RAIL BASE, RH	-
7	2	ROD POINT BRACKET ASSY	-
8	1	POINT DETECTOR	-
9	1	LOCK ROD, CONNECTOR, FOR US&S M23 SWITCH MACHINE	-
10	1	DROP LUG FOR US&S M23 SWITCH MACHINE DRIVE BAR	-
11	1	BOLT, 7/8" DIA x 3" LONG, DRILLED 2 9/16" BELOW HEAD, HEAVY HEX, GR 5	-
12	1	NUT, 7/8" DIA SLOTTED HEAVY HEX, GR 8	-
13	1	SPRING WASHER, 7/8" DIA	-
14	1	COTTER PIN, 3/16" DIA x 1 3/4" LONG	-

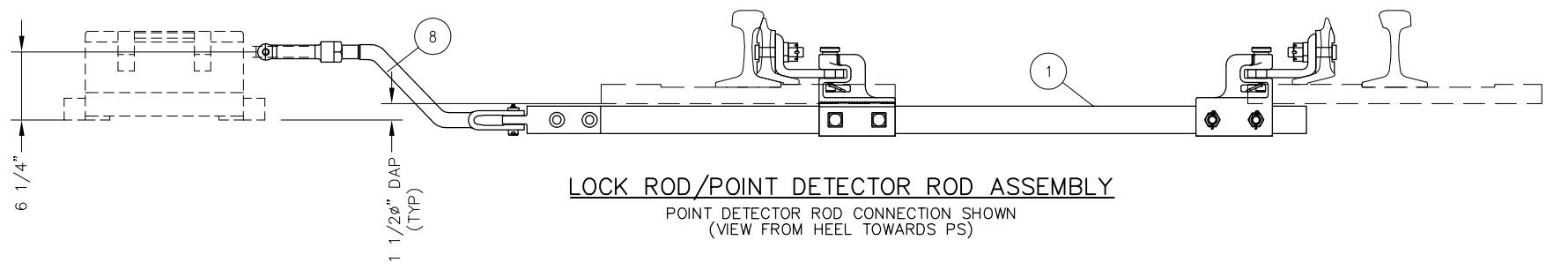
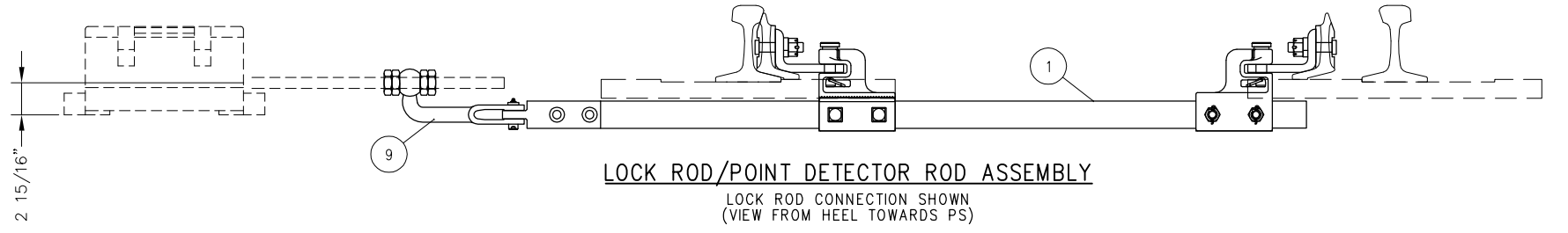
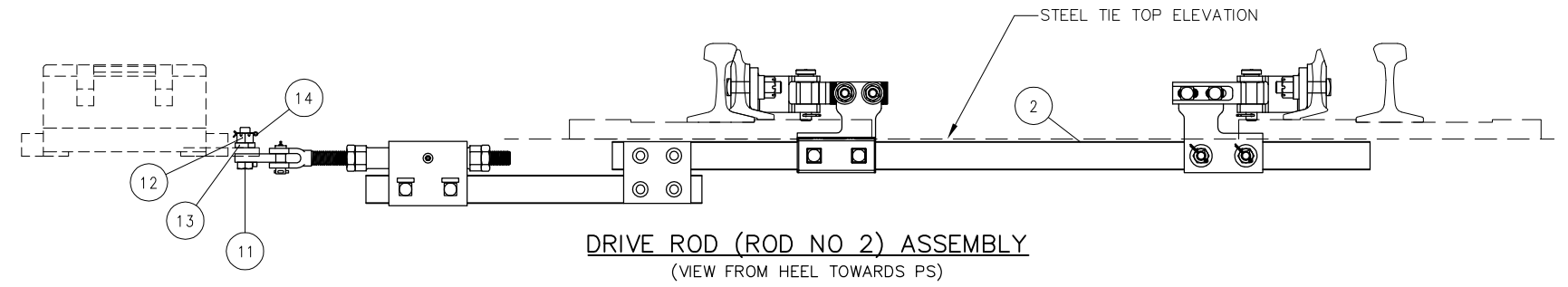
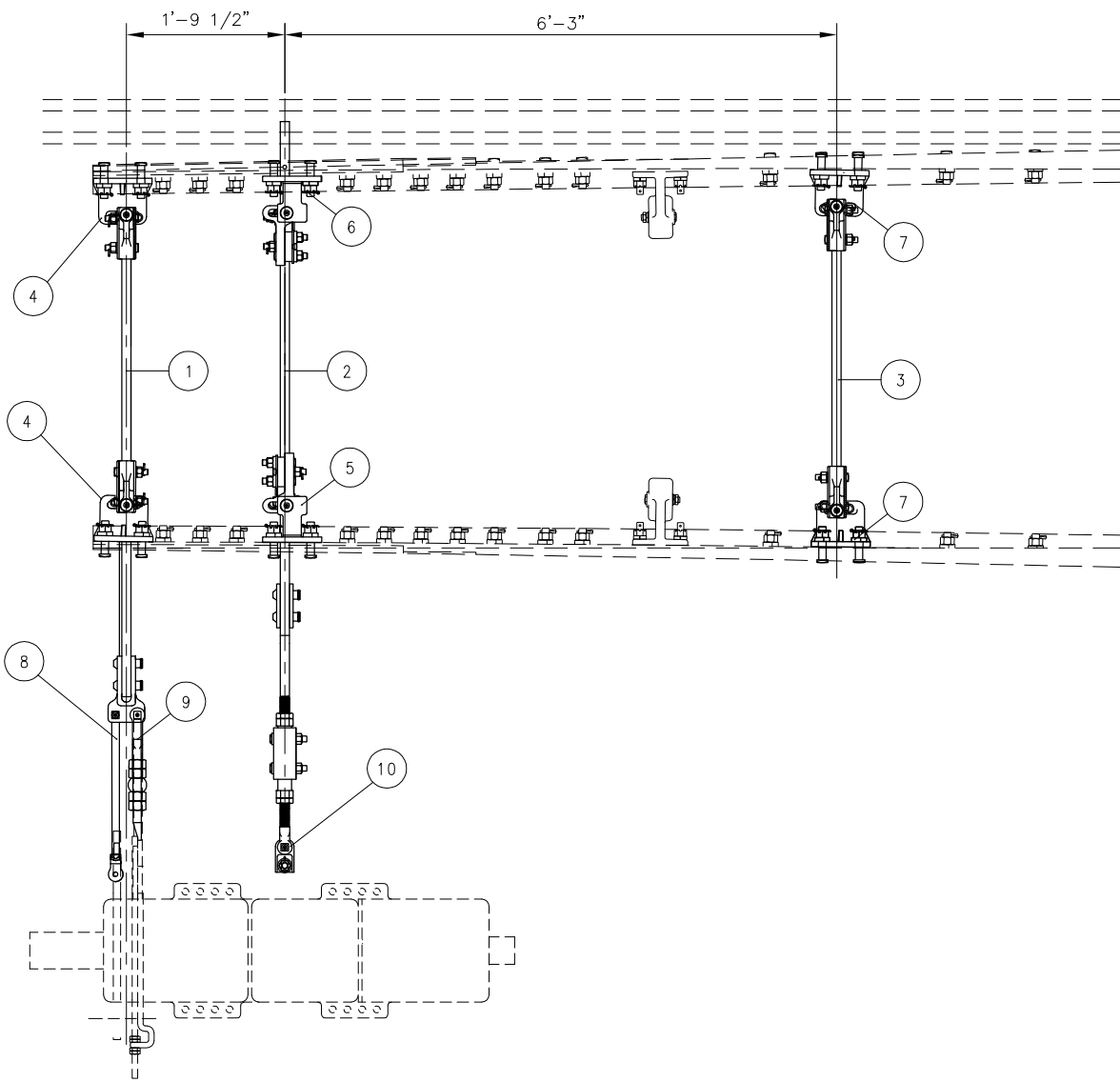

REV	DATE	BY	CHK	APP	DESCRIPTION

PENINSULA CORRIDOR JOINT POWERS BOARD

APPROVED BY:

Bernard Anagnostis *Steph Chen*

ENGINEERING MANAGER DEPUTY DIRECTOR OF ENGINEERING



1250 San Carlos Avenue
San Carlos, CA 94070

STANDARD DRAWINGS

SPECIAL TRACKWORK
NO 10 TURNOUT
HOLLOW STEEL TIE ROD ASSEMBLY
SWITCH MACHINE ON RH SIDE

CADD FILE NO.:	SD-2538
REV	DATE
0	093011
SPECIAL TRACKWORK	
STANDARD NO.:	SD-2538