

BILL OF MATERIAL				
ITEM	QTY FOR LOCK1-LH	QTY FOR LOCK2-LH	DESCRIPTION	DWG NO
1	1	1	FLAT BAR, ASTM A36, 3/4" x 8" x 2'-11" LONG	-
2	2	2	FILLER PLATE - 1" x 8" x 3"	-
3	3	3	BOLT HEX 7/8"-9UNC-2A x 3 1/2" LONG	-
4	3	3	NUT HEAVY HEX 7/8" UNC J995-GR8	-
5	3	3	WASHER FLAT 7/8" DIA BOLT	-
6	3	3	WASHER SPRING 7/8" SQ EDGE	-

NOTES:

1. ALL TOLERANCES $\pm 1/32"$ UNLESS OTHERWISE SPECIFIED.
2. STAMP PLATE I.D. CLEARLY AS SHOWN.
3. HARDWARE SHALL COME FULL ATTACHED TO PLATE.

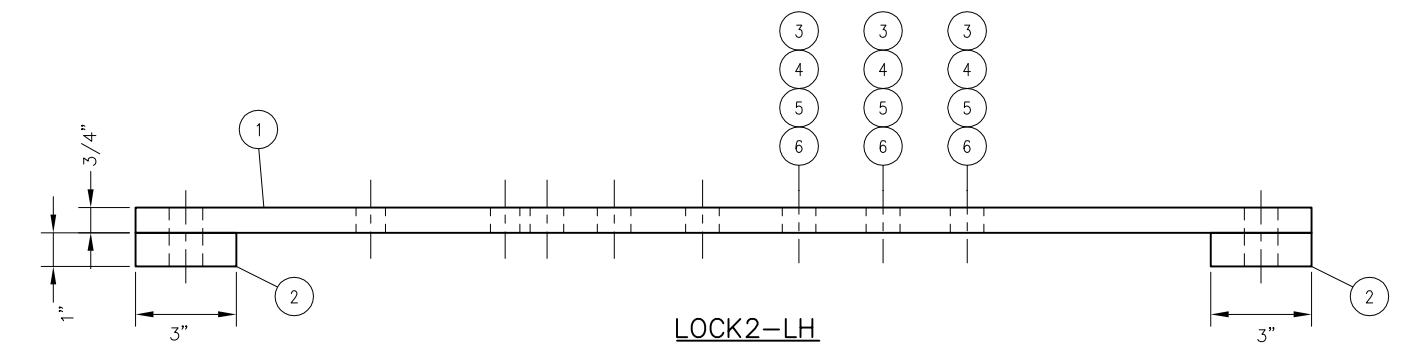
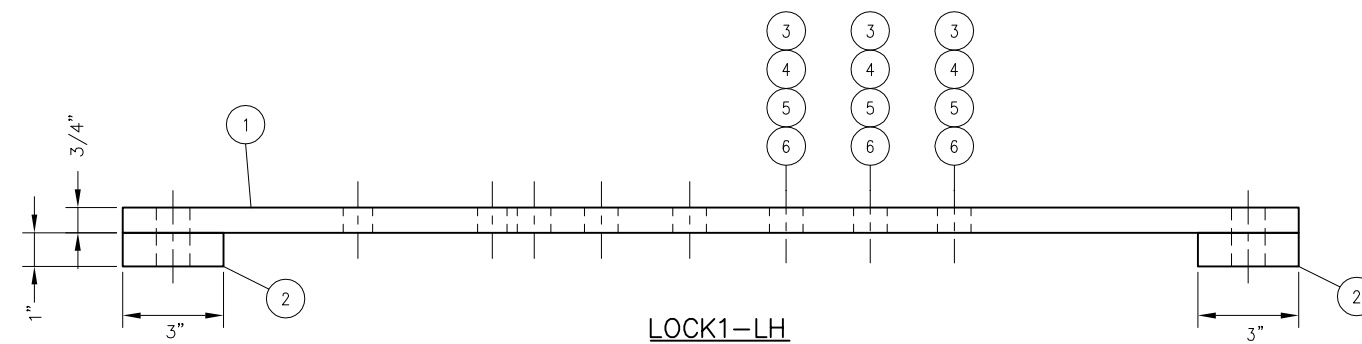
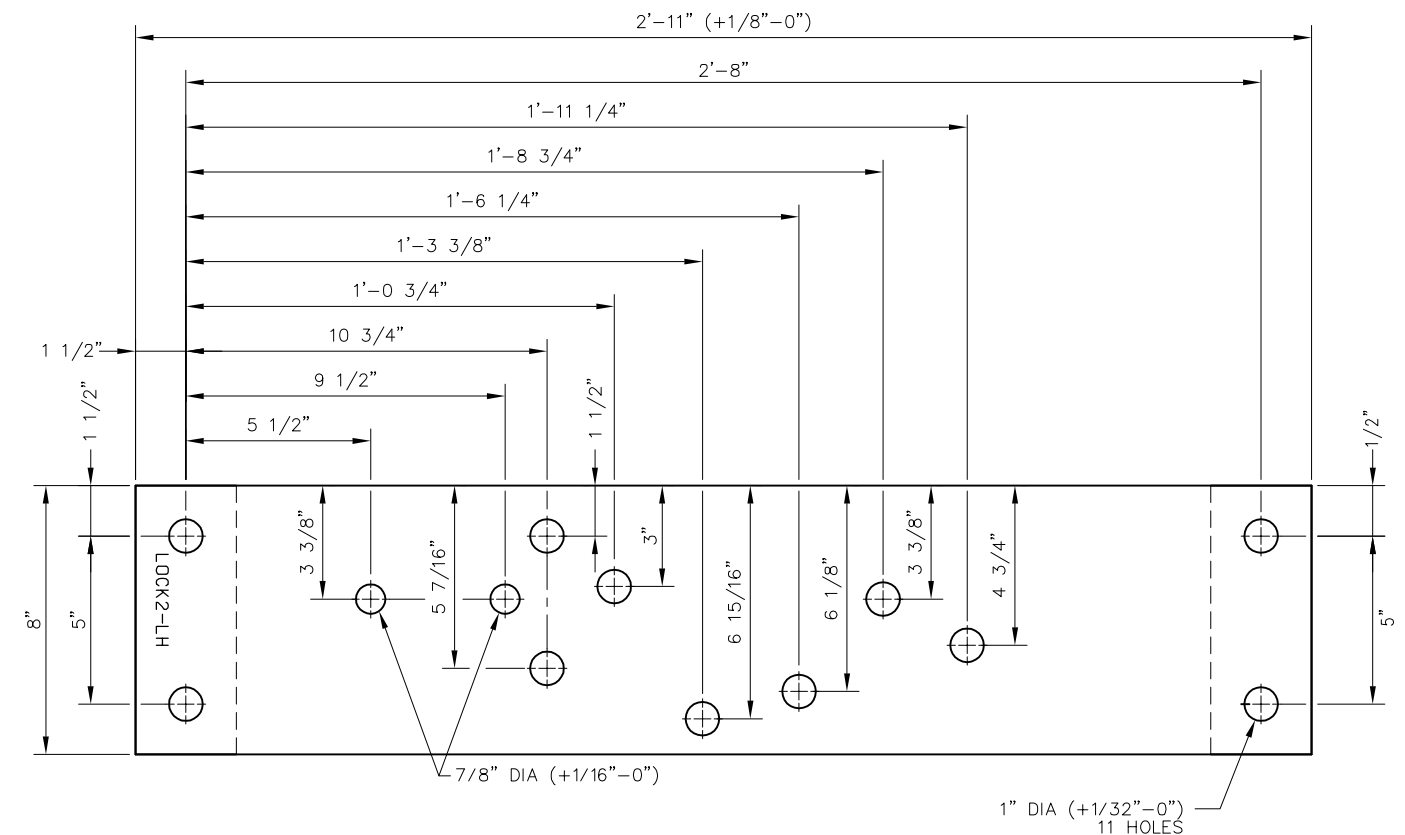
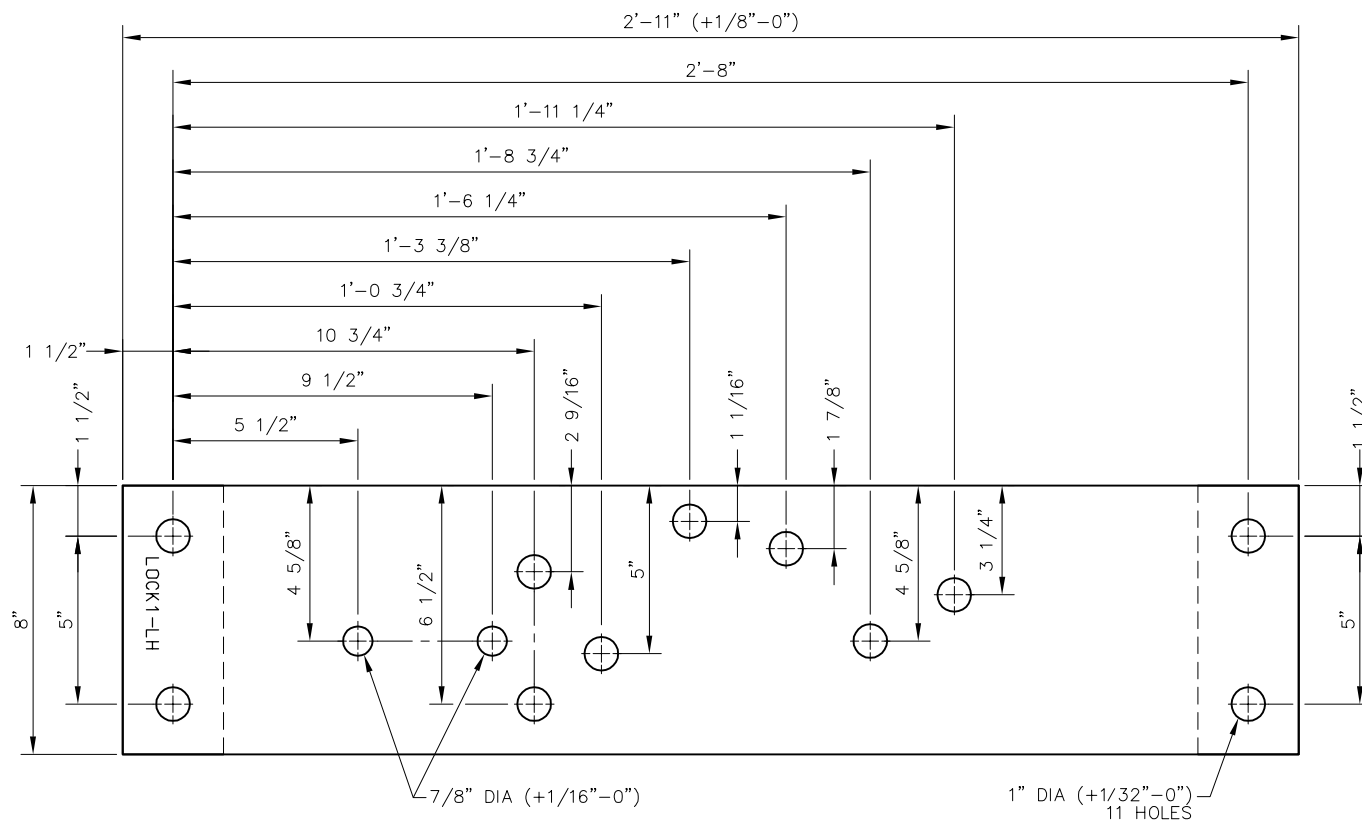

REV	DATE	BY	CHK	APP	DESCRIPTION

PENINSULA CORRIDOR JOINT POWERS BOARD

APPROVED BY:

Bernard Anagnostis *Steph Chen*

ENGINEERING MANAGER DEPUTY DIRECTOR OF ENGINEERING



STANDARD DRAWINGS

SPECIAL TRACKWORK
NO 10 TURNOUT
LH SWITCH STAND ADAPTER PLATES
FOR 36E SWITCH STAND WITH ELECTRIC LOCK

CADD FILE NO.: SD-2535	
REV 0	DATE 093011
SPECIAL TRACKWORK	
STANDARD NO.: SD-2535	