

NOTE:

1. COORDINATE SWITCH MACHINE AND MACHINE PLATES (NIC) WITH CALTRAIN

BILL OF MATERIAL			
ITEM	QTY	DESCRIPTION	DWG NO
1	1	RODDING ASSEMBLY FOR NO 10-136 LB RE, SWITCH MACHINE ON RH SIDE	SD-2538
2	1	HOLLOW TIE ASSEMBLY (HT-1LR-10-136)	-
3	1	HOLLOW TIE ASSEMBLY (HT-2LR-10-136)	-
4	1	HOLLOW TIE ASSEMBLY (HT-5L-10-136)	-
5*	2	COVER PLATE NO1, HOLLOW SWITCH TIE	-
6	6	LV BRACE FOR 136 LB RE	-
7	6	SERRATED WASHER FOR LV BRACE	-
8	6	CLIP, PANDROL, FC1601	-
9	6	CLIP, PANDROL, E2055	-
10	12	RAIL ANCHOR, UNIT DRIVE-ON TYPE 5	-
11	2	STEEL COVER PLATE FOR HST TIE, TOP END	-
12	20	PUSH PIN ASSEMBLY FOR HST COVERS	-
13	2	STEEL SIDE END COVER PLATE ASSEMBLY FOR HST TIE	-
14	4	COVER SUPPORT BRACKET	-
15*	1	COVER PLATE NO2, HOLLOW SWITCH TIE	-
16	3	HST SWITCH PLATE HTP-206-STR	SD-2305
17	2	HST SWITCH PLATE HTP-200-L	SD-2308
18	1	HST SWITCH PLATE HTP-204-L	SD-2310
19	6	SIDE POST INSULATOR FOR FC1600 SERIES PANDROL FAST CLIP	SD-2313
20	6	TOE INSULATOR FOR FC1600 SERIES PANDROL FAST CLIP	SD-2314

* NOT SHOWN ON ASSEMBLY FOR CLARITY

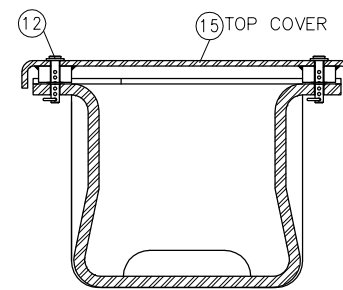

HOLLOW TIE TOP COVER DETAIL

A SECTION
SCALE: NTS

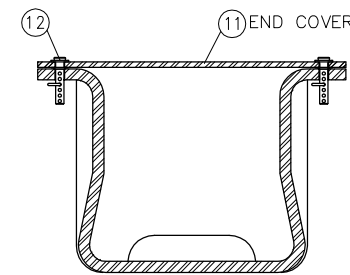

END COVER PLATE

B SECTION
SCALE: NTS

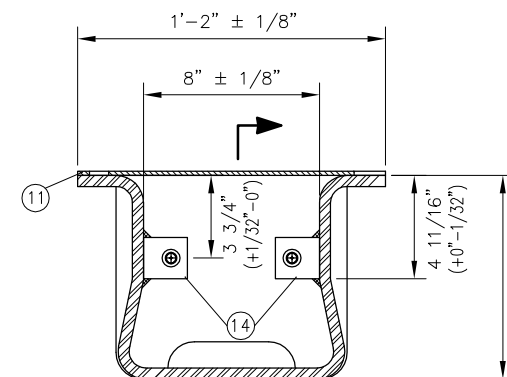

HOLLOW TIE SIDE END COVER DETAIL

C SECTION
SCALE: NTS

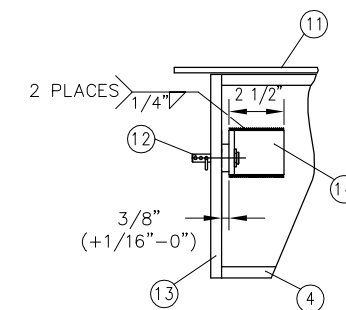



WELDING DETAIL

D SECTION
SCALE: NTS

REV	DATE	BY	CHK	APP	DESCRIPTION

PENINSULA CORRIDOR JOINT POWERS BOARD

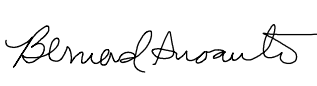
APPROVED BY:

ENGINEERING MANAGER DEPUTY DIRECTOR OF ENGINEERING



1250 San Carlos Avenue
San Carlos, CA 94070

STANDARD DRAWINGS

SPECIAL TRACKWORK
NO 10 TURNOUT
HOLLOW STEEL TIES FOR LH TURNOUT
SWITCH MACHINE ON MAINLINE SIDE

CADD FILE NO.:	SD-2520
REV	DATE
0	093011
SPECIAL TRACKWORK	
STANDARD NO.:	SD-2520