

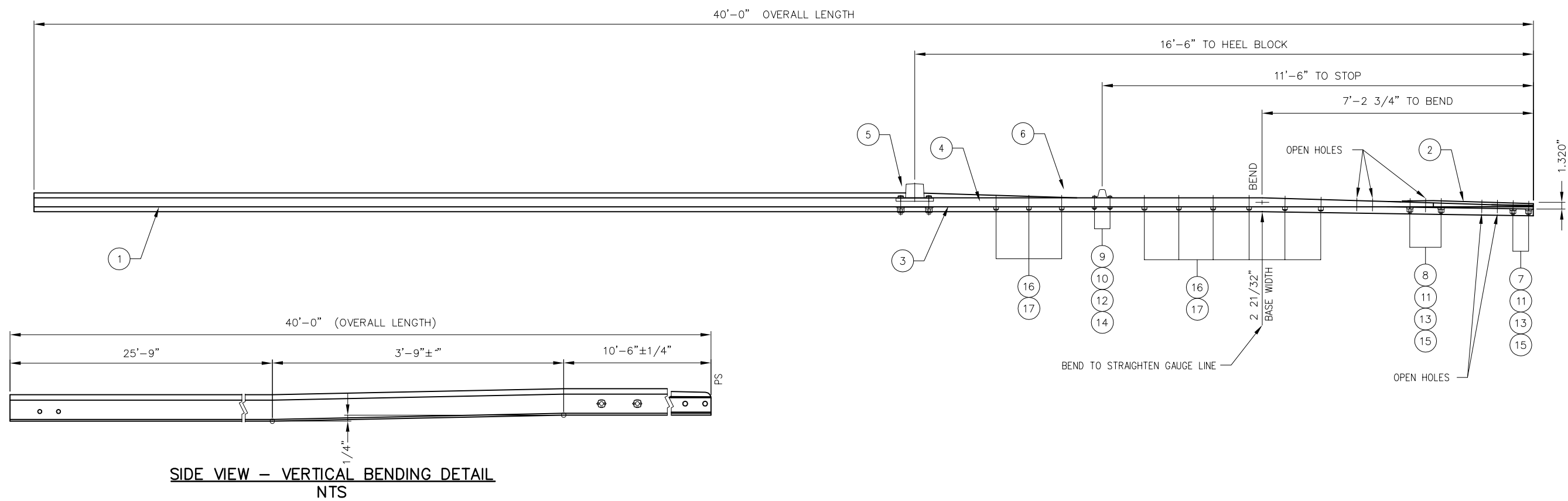

BILL OF MATERIAL				BILL OF MATERIAL			
ITEM	QTY	DESCRIPTION	DWG NO	ITEM	QTY	DESCRIPTION	DWG NO
1	1	SWITCH POINT RAIL, 136 LB RE, RH SAMSON GR, 40'-0"	ES2801-22	10	2	SPRING WASHER, 3/4" DIA	-
2	1	MANGANESE TIP RH FOR 136 LB RE 16'-6" SAMSON SWITCH POINT	-	11	4	SPRING WASHER, 1" DIA	-
3	1	REINFORCING BAR, GAUGE SIDE, 1/2" x 14'-6", RH POINT	-	12	2	NUT, 3/4" DIA HEAVY HEX, GR 5	-
4	1	REINFORCING BAR, STOCK SIDE, 1/2" x 10'-11 1/2", RH POINT	-	13	4	NUT, 1" DIA HEAVY HEX, GR 5	-
5	1	SWITCH HEEL ASSY FLOATING 132/136 LB RE C/W HARDWARE	-	14	2	COTTER PIN, 3/16" DIA x 1 3/4"	-
6	1	POINT STOP 3 1/4" HIGH	-	15	4	COTTER PIN, 1/4" DIA x 2"	-
7	2	BOLT, 1" DIA x 3 1/2", THIN SQUARE HEAD DRILLED @ 3 3/16" GR 5	-	16	9	HUCKBOLT, 3/4" DIA (C50LR-BR24-24)	-
8	2	BOLT, 1" DIA x 3 3/4", THIN SQUARE HEAD DRILLED @ 3 1/2" GR 5	-	17	9	HUCK COLLAR, 3/4" DIA (3LC-2R24G)	-
9	2	BOLT, 3/4" DIA x 4", SQUARE HEAD DRILLED @ 3 21/32" GR 5	-				



- NOTES:**
1. ROUND EDGES OF SWITCH STOPS AT CONTACT AREAS. R = 1/2"
  2. BEVEL ALL BOLT HOLES

					<b>PENINSULA CORRIDOR JOINT POWERS BOARD</b>					<b>STANDARD DRAWINGS</b>			CADD FILE NO.: SD-2402			
					APPROVED BY:					 1250 San Carlos Avenue San Carlos, CA 94070			REV 0		DATE 093011	
					 ENGINEERING MANAGER								SPECIAL TRACKWORK NO 8 TURNOUT SWITCH POINT ASSEMBLY 16'-6" STRAIGHT SWITCH POINT		STANDARD NO.: SD-2402	
REV	DATE	BY	CHK	APP	DESCRIPTION	REV	DATE	BY	CHK	APP						